

# DATA SHEET

## 4K HDMI IP Video Wall Controller

### 29-0112/29-0113 - IPVDS-500-ED

#### Contents

- Description
- Features
- Supporting Video Resolutions for Input / Output
- Applications
- Technical Specification
- EMC Test
- Block Diagram

#### OPTICIS HQ

##### Headquarters

Opticis Co., Ltd.  
# 16Fl, Kins Tower  
8 Sungnam-daero, 331 beon-gil,  
Bundang-gu,  
Seongnam-si, Gyunggi-do, 463-844  
South Korea  
Te l: +82 (31) 719-8033  
Fax: +82 (31) 719-8032 GLC-TE

Direktronik AB  
Konsul Johnsons väg 15  
SE-149 45 Nynäshamn  
Sweden  
Te l: +46 (0)8-524 00 700  
info@direktronik.se  
www.direktronik.se

## ■ Description

4K HDMI IP Video Wall Controller IPVDS-500-ED is an integrated control solution for playing audio/video of multi-sources (such as PC, Media player, DVD or Blu-ray) on video wall displays and many individual displays simultaneously.

It offers advanced wall management service in order to give perfect solution for accommodating medium-sized and larger multi-board configurations such as control room, security, traffic management and small-scale single-board systems for conference, classroom presentations.

The transmitter, IPVDS-500-E (Encoder) connected to a HDMI source, encodes the video with data and transmits it over Ethernet. The receiver, IPVDS-500-D (Decoder) connected to a display, receives the encoded signal over network and decodes it to regenerates the video and data for users.

The provided PC program “Layout Manager” makes possible the creation, editing, overlay, save and pre-set mode of wall layouts and it has an easy-to-use graphics user interface where any operation can be set up by simple mouse clicks and drags.

IPVDS-500-ED also makes the transmitters and receivers units in the network can be configured to individual IP address and helps the any of receivers can be connected simultaneously to any transmitter within the network to create a virtual cross point matrix system as well as audio and video only system widely used in Pro-AV installation.

## ■ Features

- TCP/IP based IP network: 100/1000 Base-T Ethernet with CAT5e or CAT6 cables
- Up to 4K resolution (3840x2160 at 30Hz) or 1080p at 60Hz.
- Up to 8 x 8 (up to 64 displays) Video Wall with multi-sources.
- Provides merge, overlay, and split Video Wall layouts via PC program.
- Provides preset mode for user defined layout (save and loading).
- Provides scheduling action with presets in weekly mode or sequential mode.
- M:N Virtual Matrix supported: multicasting up to 200 clients
- Provides Analog/HDMI audio input and output.
- Fast switching time / Low video latency
- Transmits HDMI/DVI, USB, RS-232, Audio, DIO signals via IP Network.
- Provides HDMI loop-thru port for Local display.
- Provides Mounting bracket (model: OPSCB): VESA 75,100 standard, Optional.
- Provides 1U rack (4 in 1 rack) and power rack (PR5V-16) with 16\*5V output, Optional

■ **Supporting Video Resolutions for Input / Output**

- HDMI 1.4 3840x2160p/24/25/30Hz
- HDMI 1.4/HDTV up to 1920x1280p60Hz
- VESA Digital up to 1920x1200p60Hz

Note: Some PC resolutions may not work properly.

■ **Applications**

- Control Room
- Traffic Control System
- Security and Education
- Digital Signage / Pro AV for Video Wall & individual display

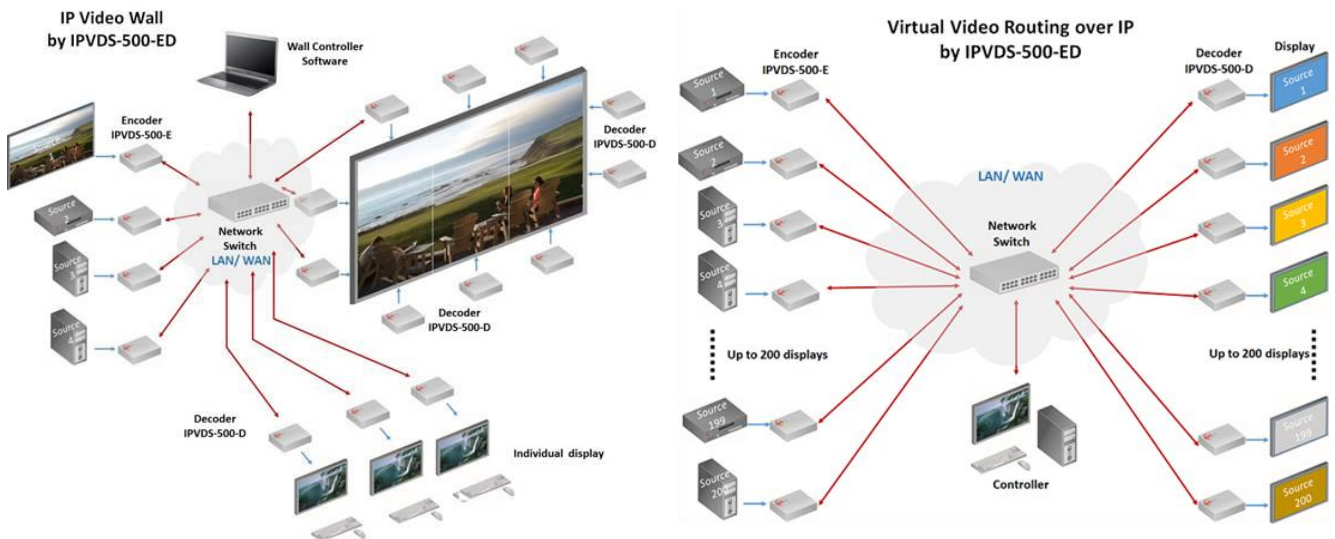

[connection diagram]

**■ Technical Specification**
**- General Specification**

Item	Description
Network	TCP/IP based IP network: 100/1000 Base-T Ethernet with CAT5e/ CAT6 Cables
Resolution	Up to 4K resolution (3840x2160 at 30Hz) or 1080p at 60Hz
Video Wall	Up to 8x8 Video Wall with multi-sources
Virtual IP Matrix	Supports MxN Virtual Matrix with individual displays
Multicast streaming	1 to N (up to 200 RXs)
Video latency & Fast switching	< 1 frame / < 2 seconds
Bit rate (changeable)	50~200Mbps(default) and Best At Best bit rate, IPVDS-500-EDs are in ' Visually lossless' .
Video Wall Control PC Program for users	<ul style="list-style-type: none"> <li>- Video Wall Controller SW Apps for Video Wall and Individual Displays</li> <li>- Provides device configuration, connection, preview, layout editing, and apply action</li> <li>- Allocation, merge, split, overlay and clear on Layout Manager</li> <li>- Provides preview scene before to apply it to real monitors.</li> <li>- Provides 99 Presets for user defined layout (Save and Loading)</li> <li>- Provides Preset Scheduling function with sequential and weekly mode</li> <li>- Bezel Compensation in 0.1mm units</li> </ul>
Video Interface Standard	HDMI 1.4 and DVI1.0
HDCP / LAN Port	HDCP 1.4 and 2.2 / RJ-45 (TX/RX 1 port)
TX Video Interface	Input: 1 HDMI/DVI Input, Output: 1 HDMI/DVI Output (Loop-Through )
RX Video Interface	Output: 1 HDMI/DVI Output
Keyboard/Mouse (TX)	1 x mini USB B type to PC   1 x USB A type (for Local HID Keyboard/Mouse)
Keyboard /Mouse (RX)	2 x USB A type ( for Remote HID Keyboard/Mouse)
Audio Input (TX)	HDMI Audio or Analog Line-in
Audio Output (RX)	HDMI Audio and Analog Line-Out (Dual output)
RS- 232 Port (optional)	3 Pin Terminal block for Knob & alarm interface
Digital I/O Port (optional)	3 Pin Terminal block for Control Authority (Externally)
Reset Switch	SW reset & Factory reset
EDID	Built-in EDID & EDID Read/Write
Dimension	TX: 112 x 28 x 104mm (WHD), RX: 112 x 28 x 104mm (WHD)
Power	100-240VAC, 50-60Hz / 5V/2A Adaptor
Power Consumption (TBD)	TX < 5W   RX < 5W
Operating Temperature	0 ~ 50°C / -20 ~ 60°C (Storage Temperature)
Certification	FCC, CE, KC

## - Electrical Characteristics

	Parameter	Symbol	Minimum	Typical	Maximum	Units	
Power Supply	Supply Voltage, Temp 25°C	VCC	+ 4.75	+ 5.0	+ 5.25	V	
	Supply Current	Tx	ITCC	-	2	-	A
		Rx	IRCC	-	2	-	A
	Power Dissipation	Tx	PTX	5.5	6.5	7.5	W
Rx		PRX	5	6	7	W	
TMDS	Data Output Load	RLD		50		Ω	
	Graphic Supply Voltage	GVCC	+ 3.15	+ 3.3	+ 3.45	V	
	Single-Ended High Level Input Voltage	GVIH	GVCC - 0.01	GVCC	GVCC + 0.01	V	
	Single-Ended Low Level Input Voltage	GVIL	GVCC - 0.6	-	GVCC - 0.4	V	
	Single-Ended Input Swing Voltage	GVISWING	0.2	-	0.75	V	
Ethernet Link	Maximum Bit rate			40		Mbps	
	Network Speed			100/1000		Mbps	
	RGMII/GMII	-0.2		2.8		V	

 (T<sub>A</sub> = 0 °C to +50 °C, unless otherwise noted)

## - HDMI Pin Description

Pin	Symbol	Functional Description
1	CH2+	TMDS Data Signal Channel 2 Positive
2	GND	TMDS Data Signal Channel 2 Shield
3	Ch2-	TMDS Data Signal Channel 2 Negative
4	CH1+	TMDS Data Signal Channel 1 Positive
5	GND	TMDS Data Signal Channel 1 Shield
6	CH1-	TMDS Data Signal Channel 1 Negative
7	CH0+	TMDS Data Signal Channel 0 Positive
8	GND	TMDS Data Signal Channel 0 Shield
9	CH0-	TMDS Data Signal Channel 0 Negative
10	CLK+	TMDS Clock Channel Positive
11	GND	TMDS Clock Signal Shield
12	CLK-	TMDS Clock Channel Negative
13	CEC	Consumer Electronics Control
14	Reserved	Not used
15	SCL	HDCP/DDC communication clock
16	SDA	HDCP/DDC communication data
17	GND	DDC/CEC shield
18	5V	5 V Input for Transmitter from Host
		5 V Output for Monitor from Receiver
19	Hot plug Detect	Signal is driven by monitor to enable the system to identify the presence of a monitor

**- Absolute Maximum Ratings**

Parameter	Symbol	Minimum	Maximum	Units
Supply Adaptor Voltage, Temp=25°C	VCC	-0.3	+5.25	V
Operating Temperature	Top	0	50	°C
Operating Relative Humidity	RHop	5	80*	%RH
Storage Temperature	Tsto	- 30	+ 70	°C
Storage Relative Humidity	RHsto	10	95*	%RH

**- Recommended Operating Conditions**

Parameter	Symbol	Minimum	Typical	Maximum	Units
Ambient Operating Temperature	TA	0		+ 50	°C
Data Output Load (HDMI)	RLD		50		Ω
Power Supply Rejection (Note1)	PSR		100		mVp-p
Supply Voltage	VCC	+ 4.75	+ 5.0	+ 5.25	V

**■ EMC Test**

- EMI: Meet FCC class A or B (ICES-003) and CE class A or B

STANDARDS		CONDITIONS
EN 55 022 (CISPR22) FCC; PART 15 SUBPART B	CE (Conducted Emission) & RE (Radiated Emission)	Meet Class A or B
EN 61000-3-2 (IEC 61000-3-2)	Harmonics	Meet Class A or B
EN 61000-3-3 (IEC 61000-3-3)	Flickers	Meet Class A or B

- EMS: Meet CE standards (EN 55024) and CISPR24 equivalents

STANDARDS		CONDITIONS
EN 61 000-4-2:1995	Electrostatic Discharge Immunity (Air: 8kv, Contact: 4kv)	Meet Criterion A or B
EN 61 000-4-3:1996	Radiated RF E-Field (80~1000 MHz) 3V/m (AM 80%, 1kHz)	Meet Criterion A or B
EN 61 000-4-4:1995	Fast Transients (5kHz, 60Seconds)	Meet Criterion A or B
EN 61 000-4-5:1995	Surge Transients	Meet Criterion A or B
EN 61 000-4-6:1996	Conducted Susceptibility (CS) Radiated Susceptibility (RS)	Meet Criterion A or B
EN 61 000-4-11:1994	Voltage Dips, Interruption & Variation	Meet Criterion A or B, and C

■ **Block Diagram**

Transmitter, IPVDS-500E: Internal schematic circuit diagram & I/O port

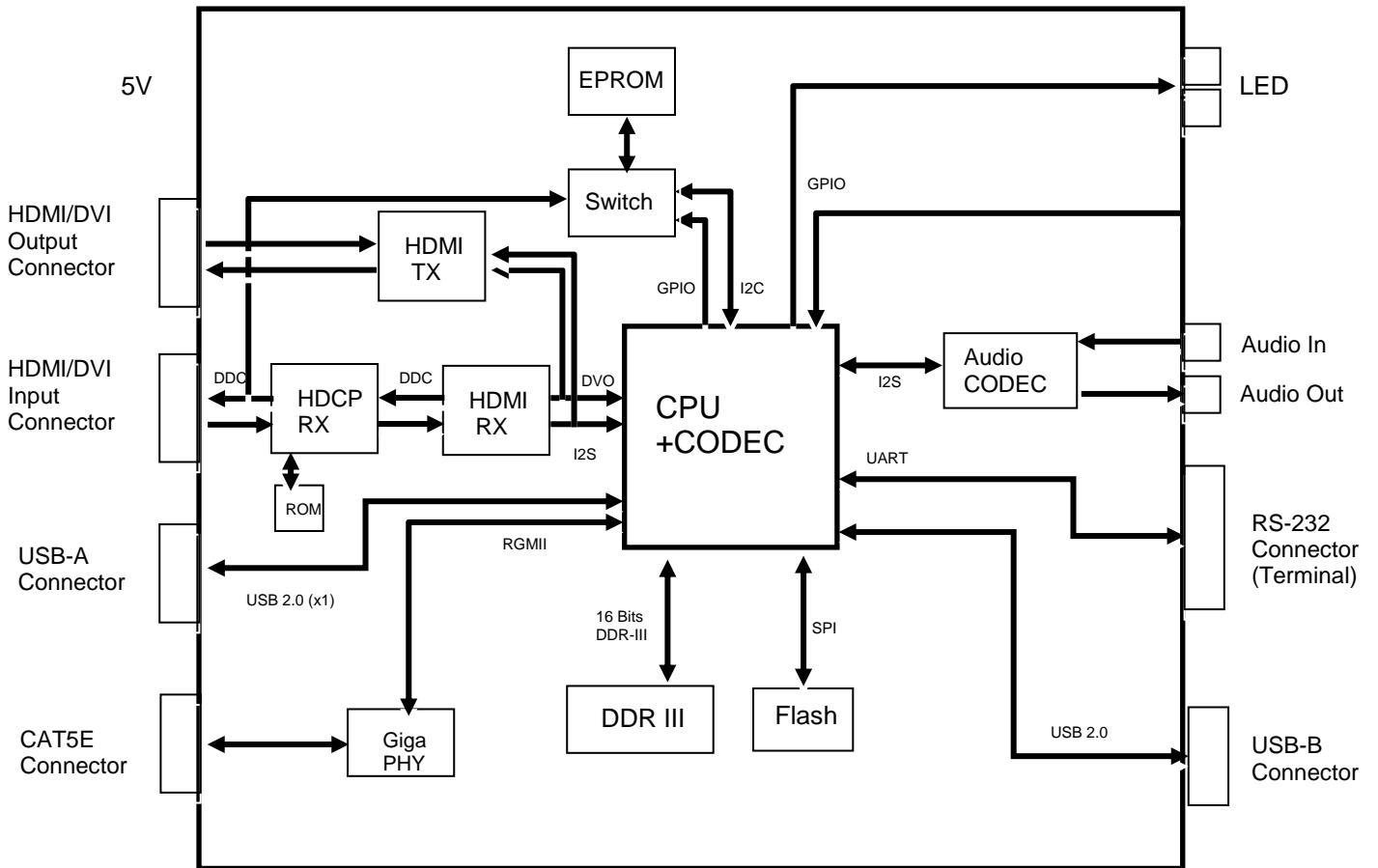

Receiver, IPVDS-500D : Internal schematic circuit diagram & I/O port

