

INSERTION AND REMOVAL

It is essential for maintaining the service life of the product, specifically the locking blade and its locking properties that the following is adhered to.

Before inserting the connector into a C13 socket, the locking blade mechanism must be disengaged by fully retracting the RED handle (Fig. 16.).

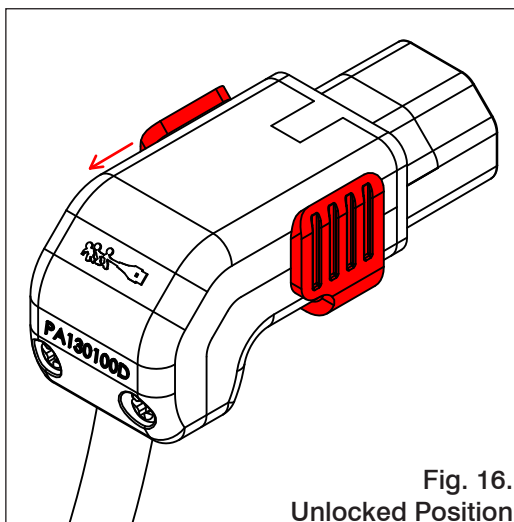
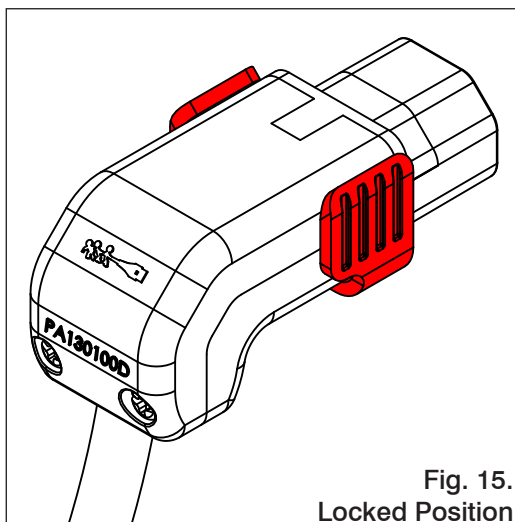

1. Insert Connector into C14 Socket (Fig. 17).

2. Release the handle to lock the connector in place (Fig. 18.).

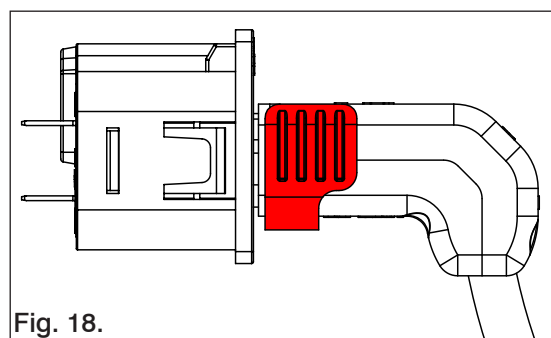
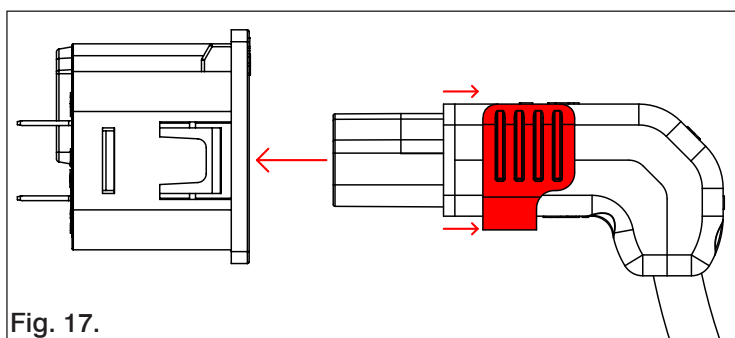

Re-Wireable C13 IEC Lock+ Connector - Down Angled

PA130100DBK Installation Guide

TECHNICAL, SAFETY AND INSTALLATION INFORMATION

Please read the following before information carefully before commencing installation.

Before commencing any electrical work, to prevent the possibility of receiving an electric shock, ensure the mains isolator on the consumer unit / fuse board is in the 'OFF' Position.

This product is rated to 10A (EU), 15A (USA/Canada) at 250V~ 50Hz and 60Hz.

STANDARDS

The rewireable IEC Lock is designed in accordance with the applicable sections of the current revision of the following documents. Where a conflict arises between these documents and statements made herein, the statements in the specification document will govern.

250V

- CSA C22.2 No. 60320-1-11. Standard for Appliance Couplers for Household and Similar General Purposes - Part 1: General Requirements - Edition 1 - Issue Date 05/12/2011
- UL 60320-1 Appliances Couplers for Similar General Purposes - Part 1: General Requirements - Edition 2 - Issue Date 05/12/2011
- IEC 60320-2-2:1998 (2nd Edition) used in conjunction with IEC 60320-1:2001 (2nd Edition)
- EN 60320-2-2:1998 (2nd Edition) used in conjunction with EN 60320-2:2001

SYSTEM DESCRIPTION

Screw-In Terminals – This product is designed to be used in accordance with cords with rating no higher than that of the product itself.

The nominal torque value for the terminal screws = 0.4Nm. The strain relief clamping screws should be tightened to 0.3Nm (2.65in-lbs).

MAXIMUM DIAMETER OF THE CORDS

| Type or Cord | Number of cores and nominal cross-section area mm ² | Amperage |
|--------------|--|-------------------|
| American | 3 x 18AWG SJT, SJE, SJ 3 x 16AWG SJT, SJE, SJ 3 x 14AWG SJT, SJE, SJ | 10A 13A 15A |
| European | 3 x 0.75 3 x 1 3 x 1.5 | 6A 10A 16A |



ENVIRONMENTAL CONDITIONS

Ambient Temperature:

- Not normally exceeding 25°C, but occasionally reaching 35°C.
- This product is rated for cold conditions.

Relative Humidity:

- 5 - 95% non-condensing, non-corrosive.

WIRING

To access the terminations, first remove fixing screws (Fig. 1.), remove the outer housing (Fig. 2.), and then remove the cable clamp (Fig. 3.).

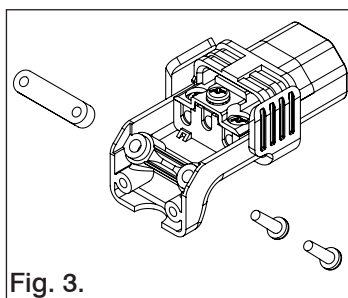
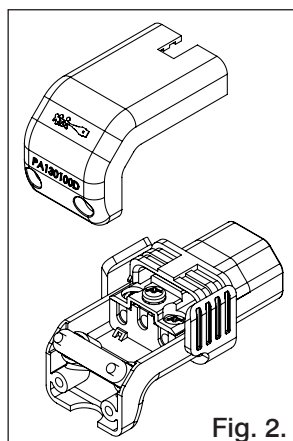
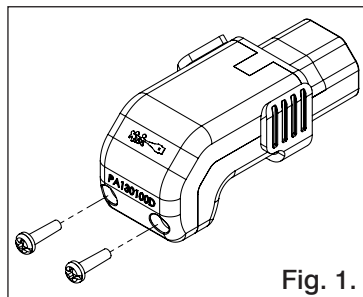

Wire the cable into the terminal (Fig. 4.) ensuring correct polarity and nominal torques values are observed (0.4Nm).

Strip cable sheathing to length (ensuring EARTH is longer than LIVE and NEUTRAL).

- Both LIVE (Phase) and NEUTRAL = 18mm
- EARTH (Ground) = 23mm

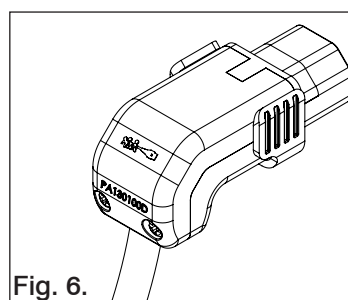
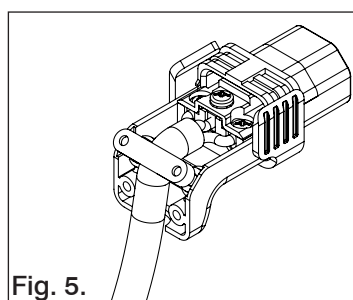
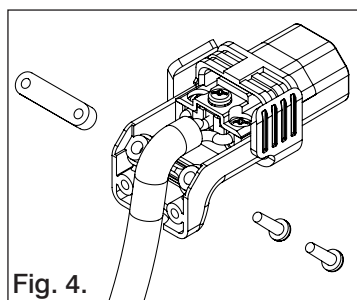

Replace the cord grip (Fig. 4 & 5.) ensuring the torque value is achieved (0.3Nm), and then replace the outer housing and screws (Fig. 6.).

CHANGING THE ORIENTATION OF THE OUTER HOUSING

The orientation of this connector can be changed from 'down-angle' to 'up-angle'. This is done by following the steps below.

1. Remove the handle from the connector by sliding forward and pulling away from the connector (Fig. 7, 8 & 9.).
2. Remove fixing screws from housing (Fig. 10.).

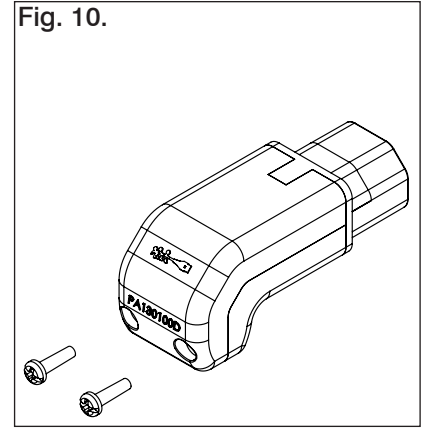
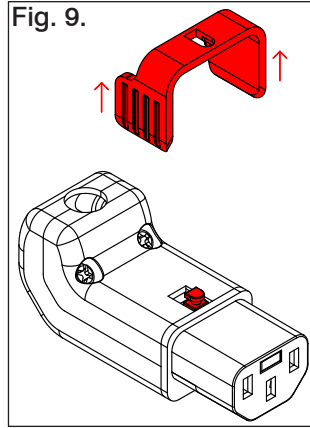
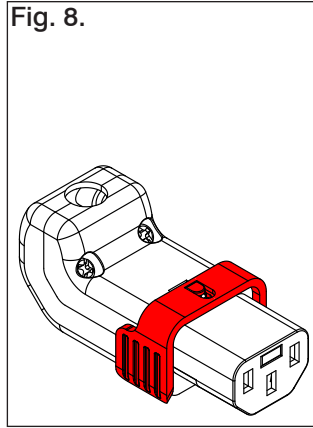
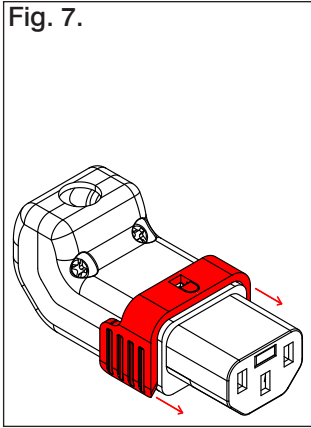

3. Remove the top and bottom outer housing (Fig. 11.).

4. Switch orientation and replace outer housing. The top housing should now be on the bottom and vice versa (Fig. 12 & 13.).

5. Once the outer housing has been replaced, the handle can be replaced (Fig. 14.).

